

Going Digital: The Techniques and Aesthetics of Phototypesetting

Charles Berret
Columbia University

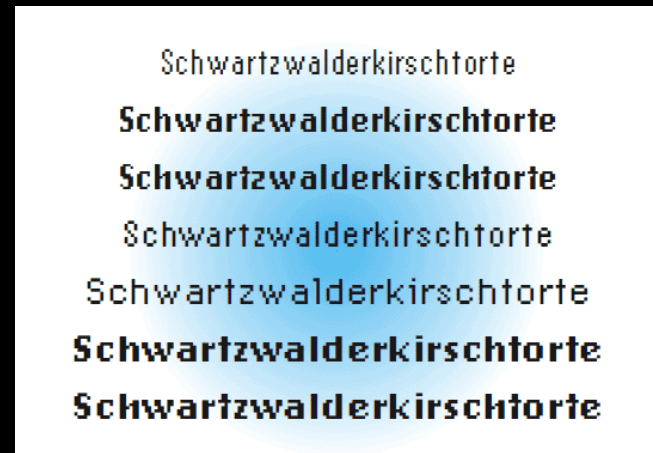

2010 Apple WWDC

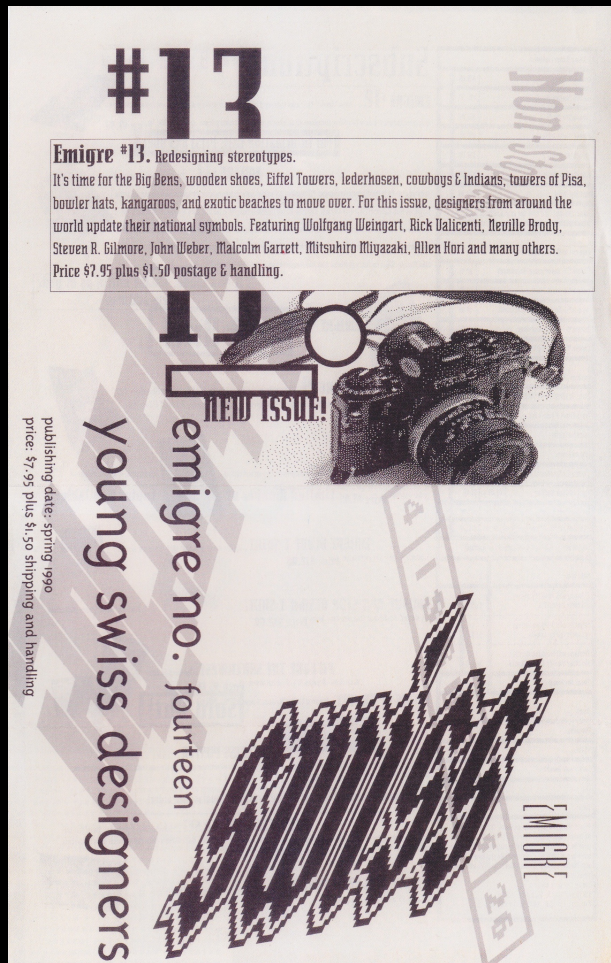

Émigré magazine (left) and typefaces (right)



Wim Crouwel's "New Alphabet" (1967)

“Electronics will soon force its claims upon letterforms, and let us hope they will liberate us from the dust of the past.”

Hermann Zapf
ATypI Paris, 1967

rtem, dolorésque co
tatis insignia, nec ap
ietate largitur? Fru
omprimimus, frustra
stra grauitatis instin
Iouis, ac D bonis ra
tes istius virtutis in C

Francesco Griffo's typework
Printed by Aldus Manutius, Venice, 1499

(No Model.)

4 Sheets—Sheet 2.

E. PORZSOLT.

APPARATUS FOR SETTING TYPE AND SIGNS BY MEANS OF PHOTOGRAPHY.

No. 568,988.

Patented Oct. 6, 1896.

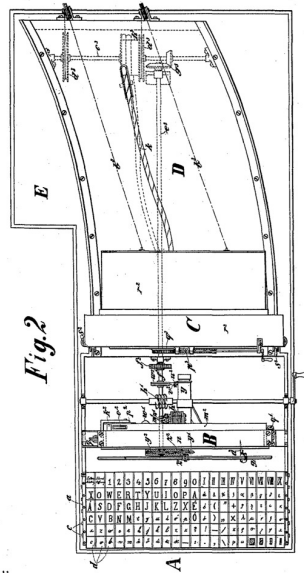

Witnesses:

L. N. Legendre.

Alfred C. Deane

Inventor

Eugene Porzsolt

By F. W. Barker

Attorney

THE PATENT OFFICE OF THE UNITED STATES OF AMERICA

Eugene Porzsolt Phototypesetter Patent (1896)

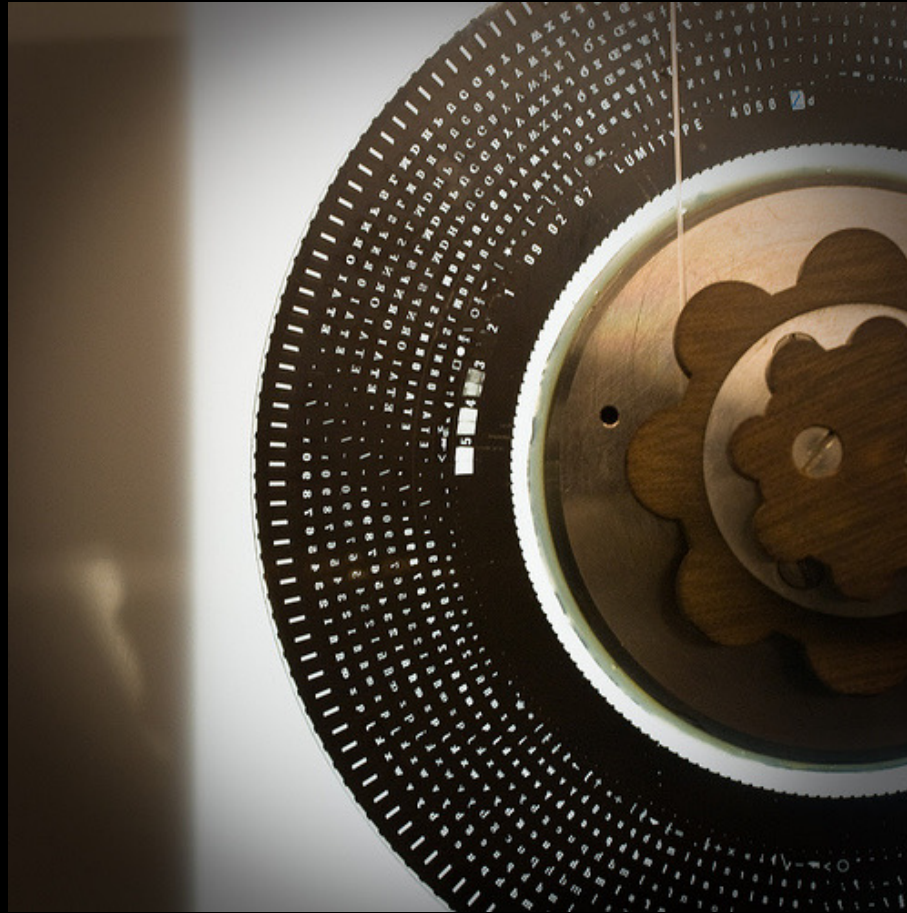

Lumitype Phototypesetter Disk (1947)

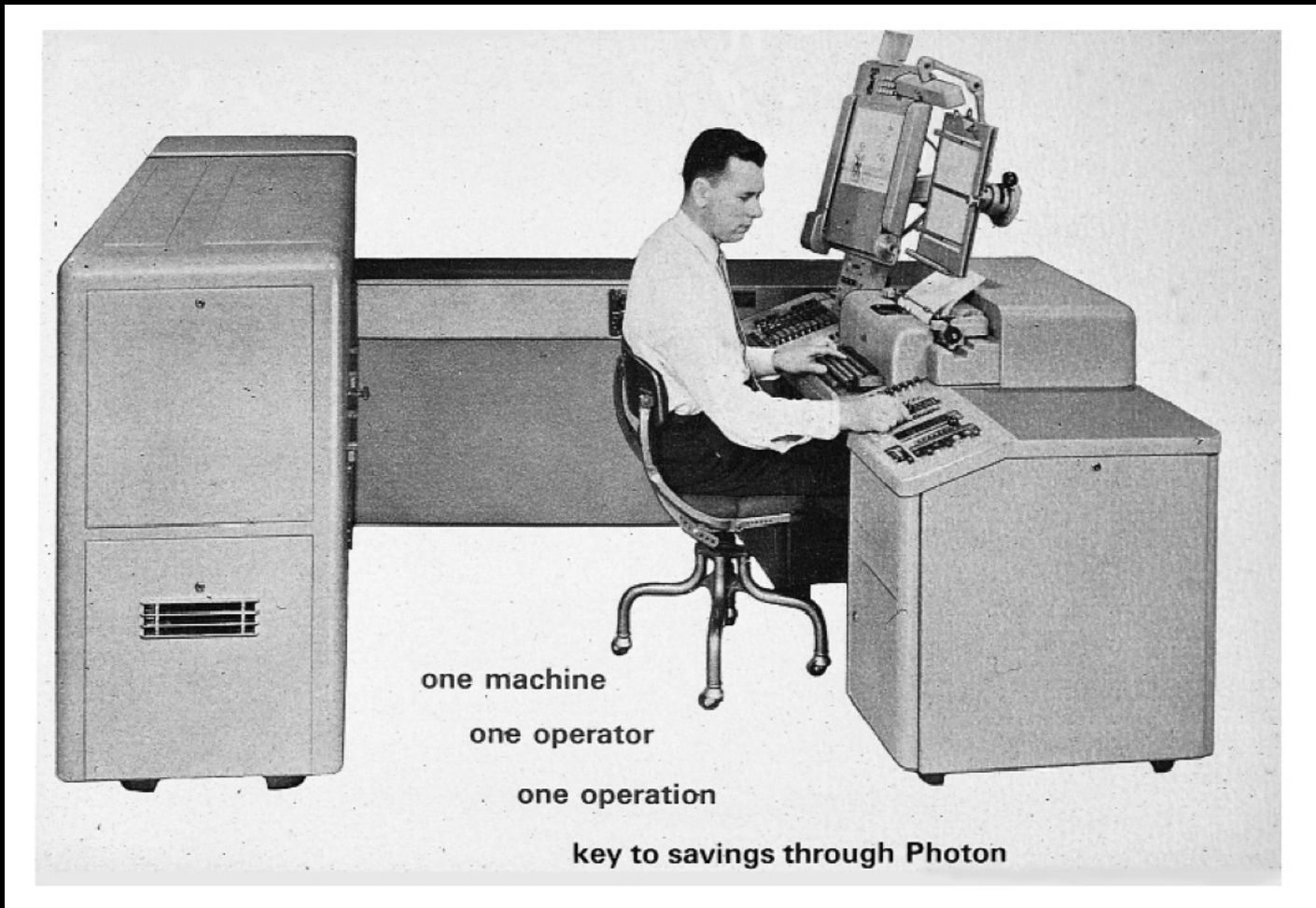

RCA Photon Phototypesetter (1954)

"I'm not exactly a stranger"

"Anyone who is acquainted with my companion casting machine will find me easy to get on with. By and large the principles of my mechanism are similar to those of a 'Monotype' Composition Caster; and it is a great advantage that I operate from the same Keyboard. Furthermore, I'm gloriously uncomplicated. You don't have to call in specialists to put me right when I'm out of sorts—not, of course, that this often happens, which is a good thing for my productivity. All in all, I'm the ideal person to know if you want an introduction to film."

Transition to filmsetting is easier with a 'Monophoto' Filmsetter

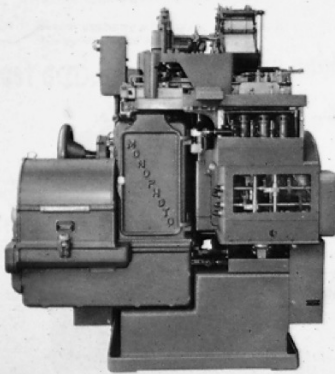

"and you know me already"



**Monotype Monophoto (1954, left)
Linotype Linofilm (195x, right)**

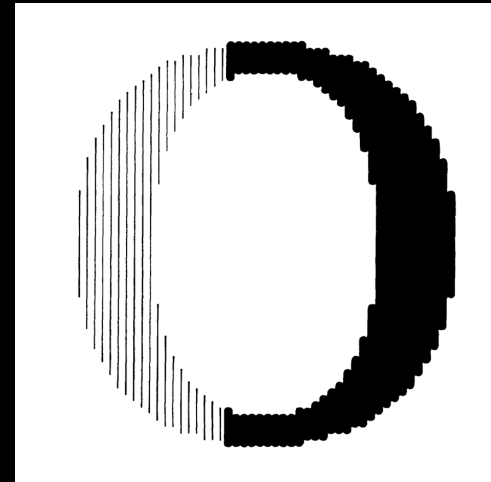

Hell Digiset (1966, left) and its Demos typeface

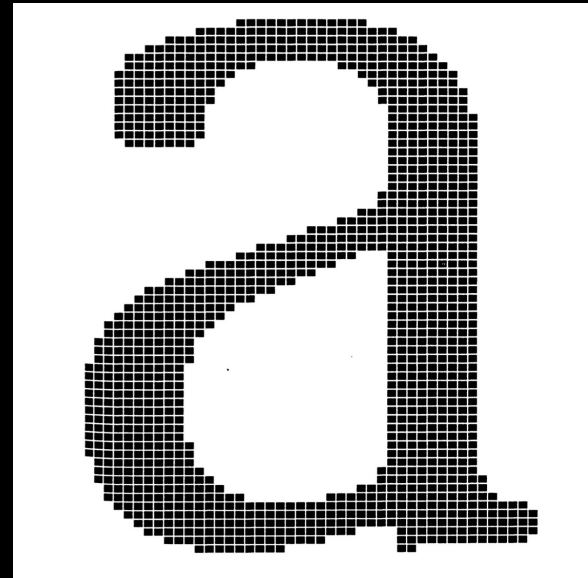

Bitmap Type Design

In Xanadu did Kubla Khan
A stately pleasure-dome decree:
Where Alph, the sacred river, ran
Through caverns measureless to man
Down to a sunless sea.

Xanadu

Antialiasing

Xanadu

Antialiasing

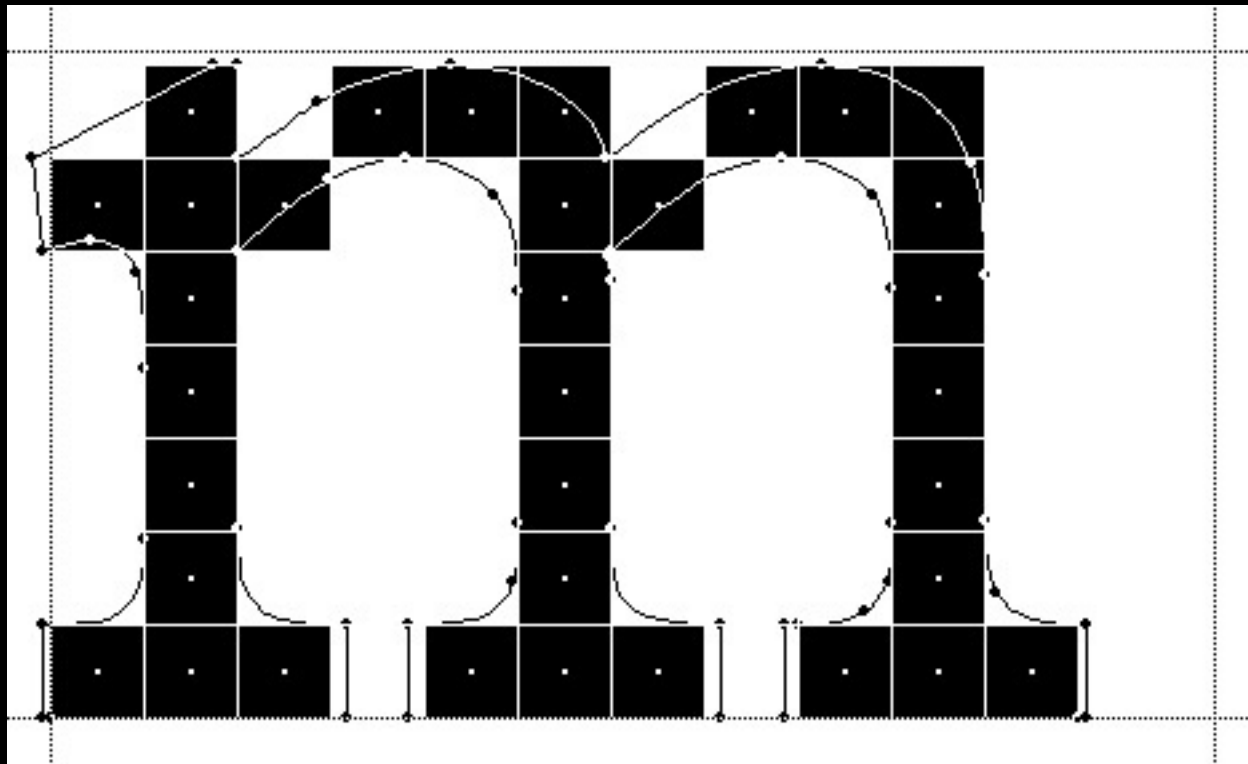

Hinting

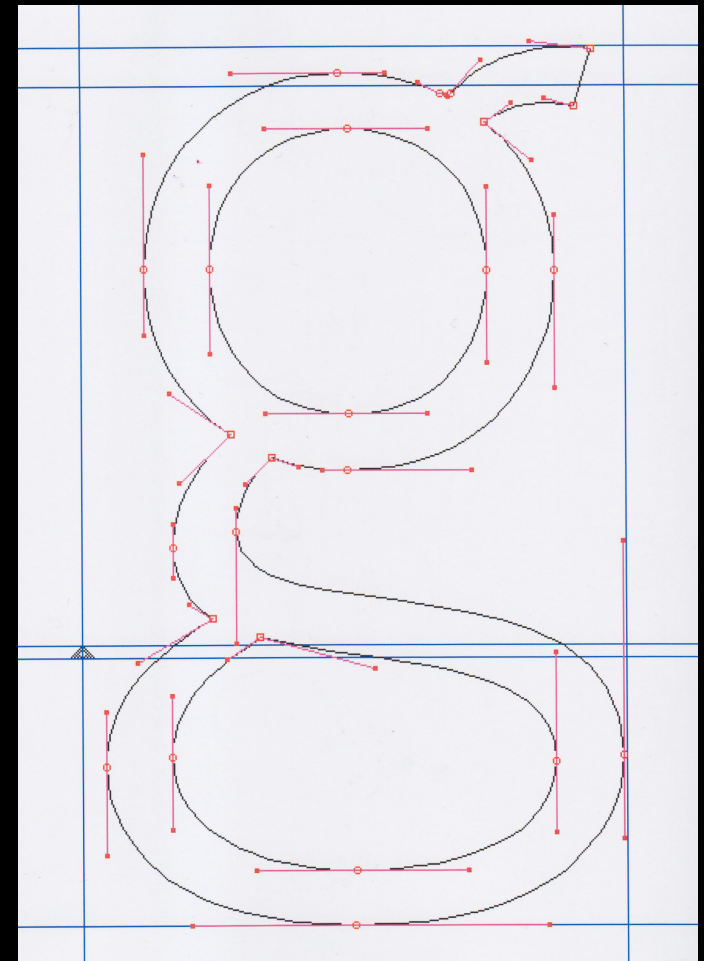
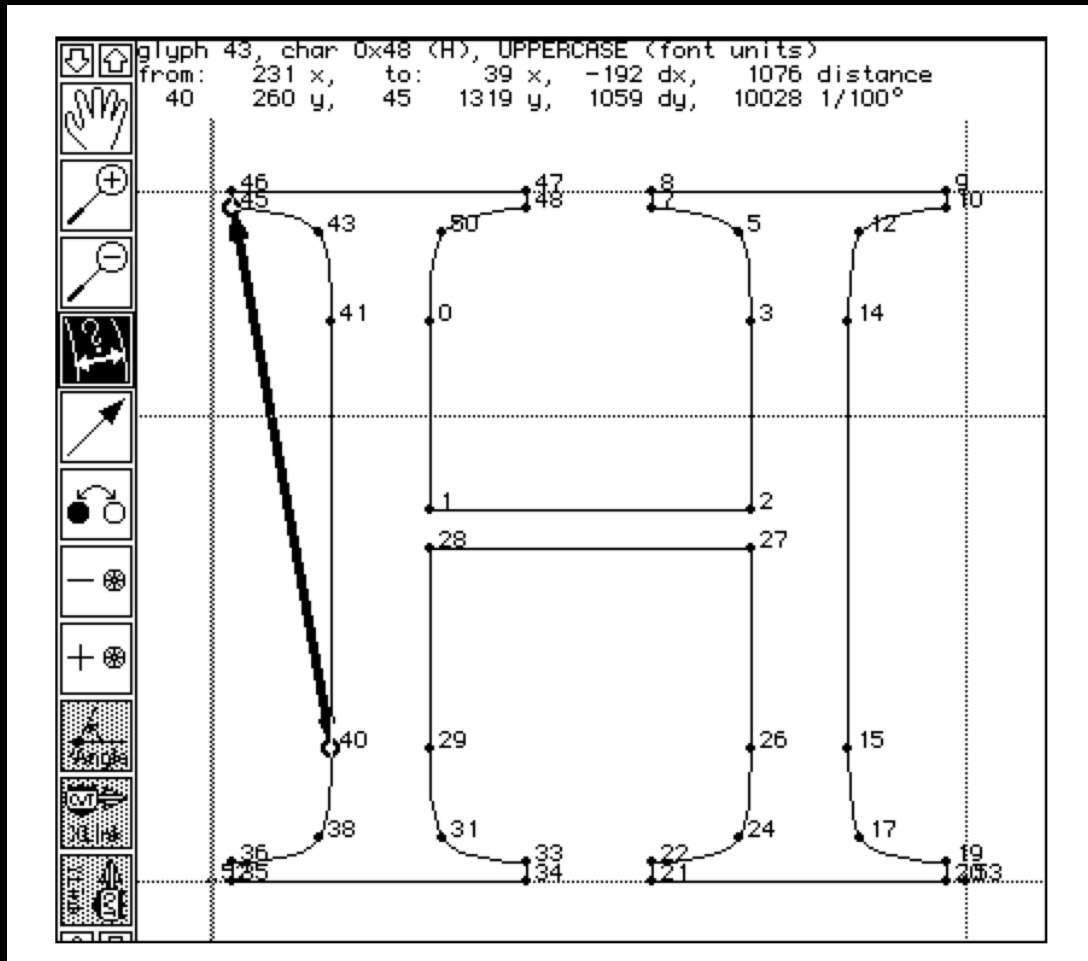

Vector-Based Type Design Software



Hermann Zapf

"The type which will now come into existence will be determined by the contemporary man who is familiar with the computer and knows how to live with it. Likewise, this type will be determined by the art of present time, with its rapidly changing character in which aesthetic values are given a totally different interpretation."

Wim Crouwel

"Type Design for the Computer Age"
Journal of Typographic Research, 1970



Beatrice Warde
"The Crystal Goblet:
Or Why Printing Should Be Invisible" (1930)

Legibility is a...

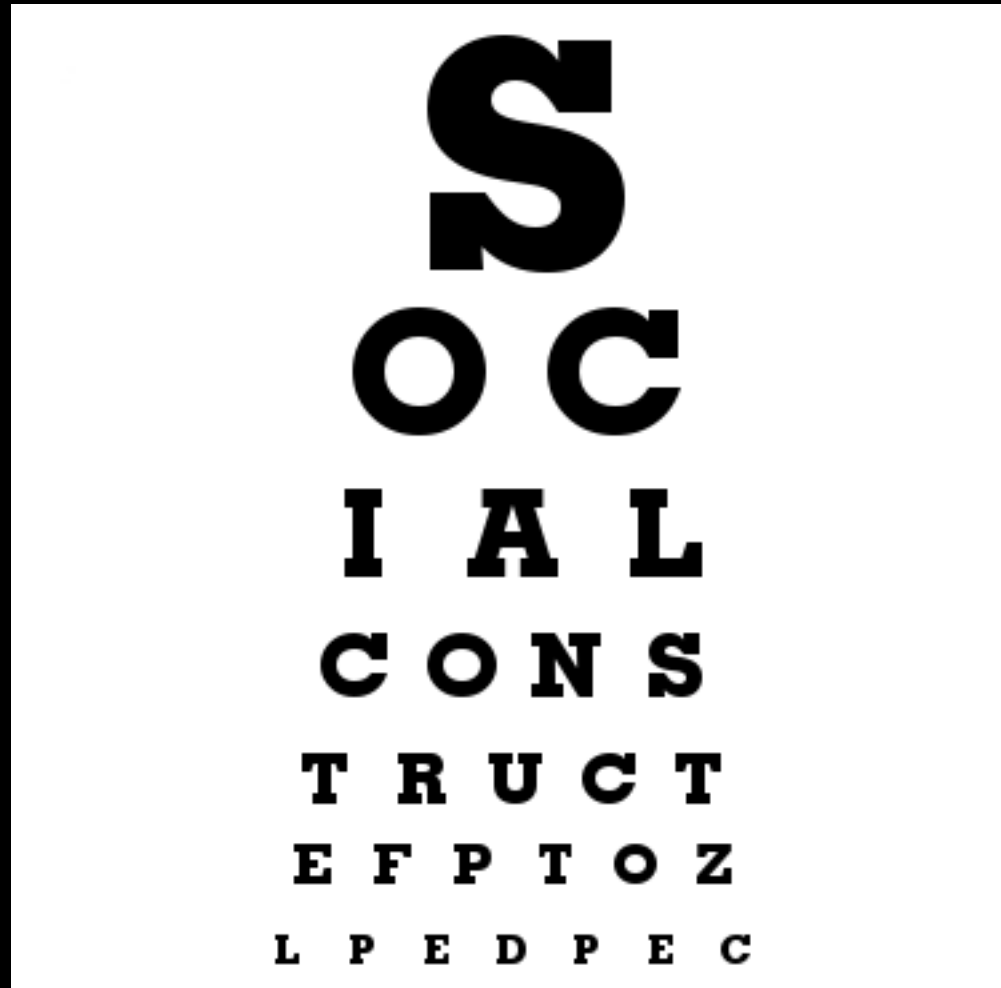

Tak.